

Storage carriage DN 20.2

One-sided mobile carriage for storage of glass sheets , cut profiles , ready products etc.
With inside and outside extensions.

Subrack	Mobile : 2 slewing 2 fixed wheels
D- length / extended [mm]	1000 / 1500
Š- width [mm]	1420
Nš - loading width [mm]	850
High [mm]	1900

NV – loading high [mm]	1500
Load capacity [kg]	1000
Weigh of paint finishing [kg]	90

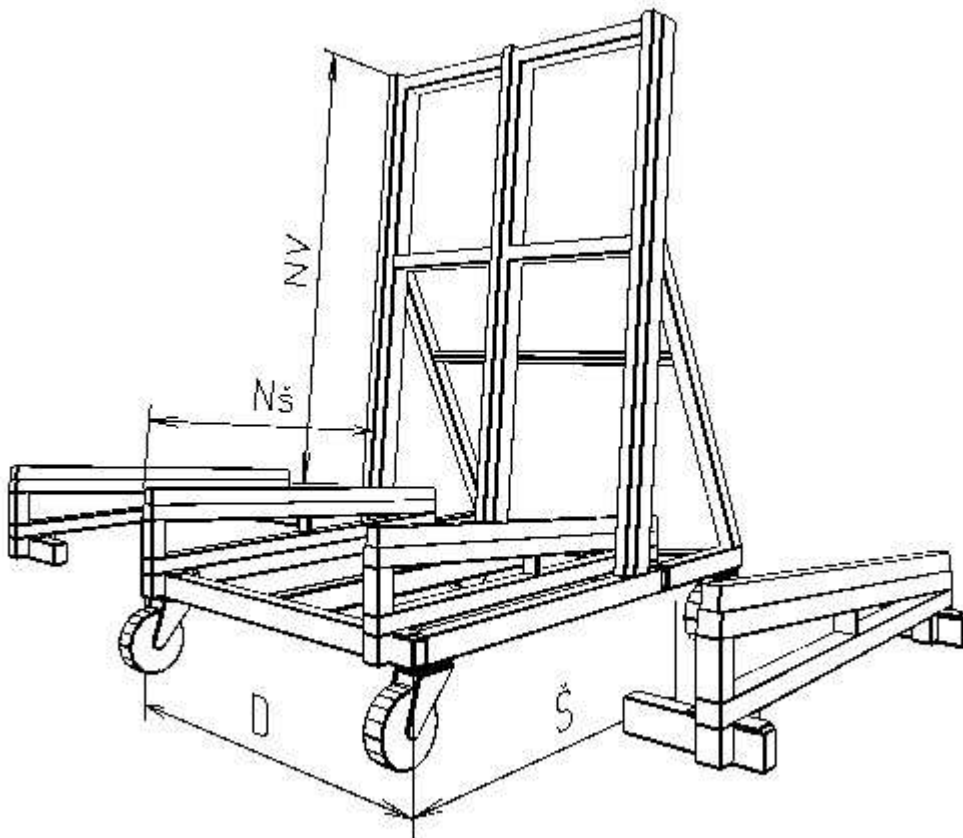

Ing.Milan Dohnal
Vývoz 5423
760 01 Zlín
Česká republika

Telefon: + 420 602566704
+ 420 603540331

e-mail: info@forset.cz